

MODEL 44, 64 & 84 'B'

P.O. BOX 80769 • 107 Commission Blvd • LAFAYETTE, LOUISIANA 70598-0769
(337) 235-9838 • FAX # (337) 235-9852 • www.sidewinderpumps.com

Pneumatic Powered — Plunger Pumps

Installation • Operation • Performance • Power Requirements
Parts Lists • Model Code • Trouble Shooting

Installation & Operating Instructions for Sidewinder Model 44 'B', Model 64 'B' & Model 84 'B' Chemical Pump

- 1) Install Model C-779-AG-S drum gauge into small bung of chemical drum and place test lever in lock position. This should block flow to drum gauge.
- 2) Install Sidewinder Chemical Injection Pump in a vertical position on drum gauge. Use ½" x ¼" NPT bushing on model 44 Sidewinder Pump which has ¼" NPT suction connection.
- 3) Connect discharge line to ¼" NPT discharge check valve. For safety, a ¼" NPT line check valve (LC-4S) is recommended for installation where discharge line connects to process line.
- 4) Connect power gas or air line to ¼" NPT supply inlet. The Sidewinder Controller accepts 10 to 150 psi.
- 5) Turn lube body #14-42 180 degrees. Screw bottle of lube oil #92-42 onto lube body. Rotate bottle and body so that bottle is upside down (do not squeeze or puncture bottle).
- 6) Unlock test lever on drum gauge, open bleeder plug #20-42-2 to remove air from pump chamber, and then close bleeder.
- 7) Set supply regulator to provide sufficient supply pressure of gas or air to firmly stroke pump against prevailing discharge pressure. (Note: If supply volume is restricted due to either too small or too long of a supply line, pump control valve will blow through or act erratic.)
- 8) Depress test lever on drum gauge so suction is taken directly from sight glass with pump stroking. Note change in gauge glass level for one full minute. Raised marks on left side of glass represent quarts per day while marks on right side represent liters per day when timed for one minute.
- 9) Adjust speed of pump by rotating Time Knob #31-42 on top of Power Head Cap #4A-44-2. Clockwise rotation decreases the number of strokes per minute. Counter-clockwise rotation increases the number of strokes per minute. Further volume control can be accomplished by varying the length of stroke with the Stroke Adjuster #1-42 also on top of the Power Head Cap.
- 10) With gauge test lever released, pump will take suction directly from drum. Gauge level will indicate volume of chemical remaining in drum.

SIDEWINDER MODEL 44, 64, 84 'B' SERIES PUMP

(USE CUTAWAY WITH SERIAL NOS. 26184 OR GREATER)

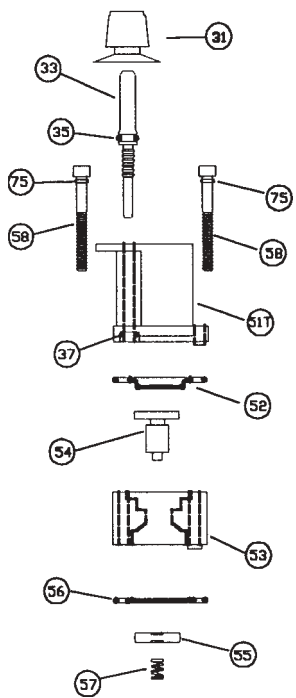
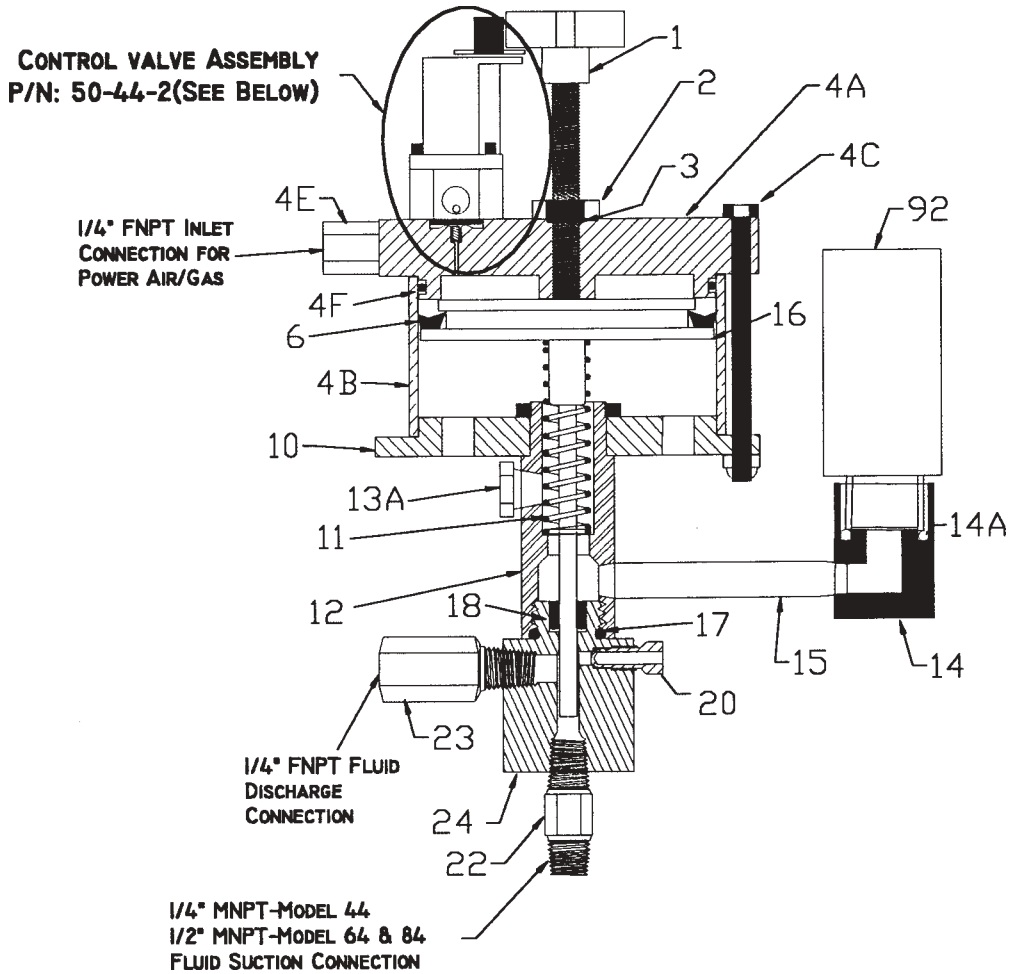

Sidewinder Pump Model Number Chart	
Fill in boxes below to determine Sidewinder Pump Size & Material Requirements	
Pump Size	Material Required
<div style="display: flex; justify-content: space-around;"> <div style="border: 1px solid black; width: 20px; height: 20px;"></div> <div style="border: 1px solid black; width: 20px; height: 20px;"></div> <div style="border: 1px solid black; width: 20px; height: 20px;"></div> </div>	<div style="display: flex; justify-content: space-around;"> <div style="border: 1px solid black; width: 20px; height: 20px;"></div> <div style="border: 1px solid black; width: 20px; height: 20px;"></div> <div style="border: 1px solid black; width: 20px; height: 20px;"></div> </div>
Plunger Size 04 0.250" 08 0.500" 16 1.000"	Check Valve & Body Material 316 SS (Standard) 2 Titanium 6
Piston Size 0 1.25" 2 2.25" 4 4.00"	Plunger Packing Teflon Graphite Uniseal 0 Viton O-Ring 2 Buna O-Ring 3 Teflon Uniseal 4 Teflon Uniseal w/Buna O-Ring Insert 4B Teflon Uniseal w/Viton O-Ring Insert 4V
Plunger Material 0 17-4 SS (Standard) 2 316-SS 3 440C SS 4 Ceramic 6 Titanium 8 316SS w/Electroless Nickel Plating 9 Special	Chemraz O-Ring 5 Hitec O-Ring 6 Teflon O-Ring 7 Polyblend Uniseal 8 Special 9 NOTE: O-Ring Seals require 2 narrow back up rings. Uniseal requires no back up rings.

PARTS LIST for MODEL 44 'B', 64 'B' & 84 'B' SIDEWINDER PUMP

Use this parts list with Serial No.'s 26184 & greater.

Item #	Description	Model 44 'B'	Model 64 'B'	Model 84 'B'
1	Stroke Adjuster	1-42	1-42	1-42
2	Locknut-Stroke Adjuster	2-42	2-42	2-42
*3	Seal-Stroke Adjuster	3-42	3-42	3-42
4A	4.00" Powerhead Cap	4A-44-2	4A-44-2	4A-44-2
4B	Powerhead Cylinder	4B-44-2	4B-44-2	4B-44-2
4C	Powerhead Tie Bolt (6 required)	4C-44-2	4C-44-2	4C-44-2
4D	Powerhead Tie Bolt Nut (6 required)	4D-44-2	4D-44-2	4D-44-2
4E	Powerhead Inlet Connector Fitting	4E-44-2	4E-44-22	4E-44-2
*4F	Powerhead Cap O-Ring	4F-44	4F-44	4F-44
*6	U-Cup (Viton U-Cup available see note 6 ^a)	6-44	6-44	6-44
7A	Mounting Tube Locknut	7A-42	7A-42	7A-42
10	Mounting Flange	10-44-B	10-44-B	10-44-B
*11	Return Spring (Spring option see note 11 ^a)	11-44	11-44	11-44
12	Mounting Tube	12C-42	12C-62	12C-82
13A	Vent	13A-42	13A-42	13A-42
14	Lube Body	14-42	14-42	14-42
14A	Lube Body O-Ring	14A-42	14A-42	14A-42
15	Lube Tube	15-43	15-43	15-43
*16	Piston-Plunger Assembly			
	<i>MATERIAL</i>			
	17-4 ph Stainless Steel	16-44	16-64	16-84
	316 Stainless Steel	16-44-2	16-64-2	16-84-2
	440 'C' Stainless Steel	16-44-3	16-64-3	16-84-3
	Ceramic	16-44-4	16-64-4	16-84-4
	Hastelloy	16-44-5	16-64-5	16-84-5
	Titanium	16-44-6	16-64-6	16-84-6
	Stainless Steel w/Chrome Plating	16-44-7	16-64-7	16-84-7
	Stainless Steel w/ Nickel Plating	16-44-8	16-64-8	16-84-8
	Customer Specified (Consult Factory)	16-44-9	16-64-9	16-84-9
*17	Mounting Tube O-Ring	17-42	17-42	17-42
*18	Plunger Seal			
	<i>MATERIAL</i>			
	Teflon Graphite Uniseal	18-42	18-62	18-82
	Techno Uniseal (Polyimede)	18-42-1	18-62-1	18-82-1
	Viton O-Ring	18-42-2	18-62-2	18-82-2
	Buna-N O-ring	18-42-3	18-62-3	18-82-3
	Virgin Teflon Uniseal	18-42-4	18-62-4	18-82-4
	Virgin Teflon Uniseal with Viton O-Ring Insert	18-42-4V	N/A	18-82-4V
	Virgin Teflon Uniseal with Buna-N O-Ring Insert	18-42-4B	N/A	18-82-4V
	Chemraz O-Ring	18-42-5	18-62-5	18-82-5
	Hitec O-Ring	18-42-6	18-62-6	18-82-6
	Virgin Teflon O-Ring	18-42-7	N/A	18-82-7
	Polyblend Uniseal	18-42-8	18-62-8	18-82-8
	Customer Specified Special (Consult Factory)	18-42-9	18-62-9	18-82-9
Note: O-Ring seals on model 44 require (1) each O-ring and (2) each narrow back up ring part number 18D-42;				
O-Ring seals on model 64 require (2) each O-ring and (3) each narrow back up ring part number 18D-62;				
O-Ring seals on model 84 requires (1) each O-ring and (2) each narrow back up ring part number 18D-82.				
20	Bleeder Valve (316 SS)	20-42-2	20-42-2	20-42-2
*22	Suction Check Valve (316 SS)	22-42-2	22-82-2	22-82-2
*23	Discharge Check Valve (316 SS)	23-42-2	23-42-2	23-42-2
24	Fluid Pump Chamber (316 SS)	24-42-2	24-62-2	24-82-2
31	Time Knob	31-42	31-42	31-42
33	Timer Stem	33-42	33-42	33-42
**35	Timer Stem O-Ring	35-42	35-42	35-42
**37	Timer Seat O-Ring (Teflon)	37-42	37-42	37-42
51	Control Valve Cover with Timer	51T-42-2	51T-42-2	51T-42-2
**52	Control Valve Diaphragm	52-42	52-42	52-42
53	Control Valve Body	53-44-2	53-44-2	53-44-2
**54	Control Valve Actuator	54-42	54-42	54-42
**55	Control Valve Poppet	55-42	55-42	55-42
**56	Control Valve Body Seal	56-42	56-42	56-42
**57	Control Valve Spring	57-42	57-42	57-42
**58	Control Valve Mounting Screw (2 required)	58-42	58-42	58-42
**75	Control Valve Mounting Screw Locknut (2 required)	75-42	75-42	75-42
*91	Piston Grease (not shown)	91-42	91-42	91-42
*92	Plunger Lube (2 Oz.) (not shown)	92-42	92-42	92-42

* Parts included in a pump end repair kit. Also included is 91-42 Silicon Piston Grease. This Kit is designated by a "K" preceding the pump model number.

The B & C series in the Model 44/64/84 pumps use the same Pump End Repair Kit.

** Parts included in timer valve repair kit. The kit part number is KVC-40.

6^a Piston U-Cup in Viton — part # 6-44-4.

Trouble Shooting The Sidewinder Chemical Pump

Problem	Possible Cause	Action
Control Valve Not Cycling	<ul style="list-style-type: none"> No supply pressure Pump speed control closed Leak in control or valve Supply gas blowing through to exhaust due to speed control too wide, trash under valve Seat or restriction in air/gas supply line. 	<ul style="list-style-type: none"> Check gauge on supply line near pump to verify adequate supply pressure . . . 10 to 150 psi. Rotate dial CCW three turns from full in position and then set desired rate. Rotate CW to slow pump rate. Check for leak, pinched or missing seals, broken diaphragm or loose mounting screws. Rotate control dial CW to decrease setting. Block exhaust momentarily and then release. DO NOT USE BARE FINGERS. If this does not work, replace Timer Seat O-Ring #37-42 or increase supply line size and move pump closer to air/gas supply source.
Piston Not Stroking	<ul style="list-style-type: none"> Return spring broken Piston stuck due to lack of Piston or Plunger Lube Supply pressure too low to buck process line pressure Stroke Length Adjuster screwed too far 	<ul style="list-style-type: none"> Replace Spring Clean and lubricat power head and piston with Piston Lube #91-42. Clean Plunger Lube Chamber and fill Plunger Lube #92-122. Change piston and plunger seals if needed. Divide process line pressure by amplification ratio (see Performance Chart). Supply pressure must exceed the result. (Standard Sidewinder Control operates from 10 to 150 psi.) Back out on stroke adjuster to desired setting.
No Fluid Discharge With Control Cycling And Piston Stroking	<ul style="list-style-type: none"> Air or vapor in pump chamber Fluid flow to pump blocked by plugged line, closed valve, extremely high viscosity or lack of fluid supply Suction or discharge check valve leaking Discharge line plugged 	<ul style="list-style-type: none"> Open bleeder valve, fill chamber with fluid only, then close bleeder valve. Provide free flow of fluid to pump suction. Use drum gauge with handle in test position to determine which valve is leaking. Clean or replace faulty valve. Clear or replace line.
Premature Seal Failure	<ul style="list-style-type: none"> Chemical incompatibility between seal and material being pumped Scored or damaged plunger Abrasive material in chemical No lubricant or incorrect lube 	<ul style="list-style-type: none"> Check a Compatibility Chart or consult chemical manufacturer, and install seal made from compatible material. Replace plunger. Install suction filter. Use Sidewinder Lube #91-42 on piston and #92-122 on plunger. Periodically check lube level.

Pump Selection Guide and Performance Chart

Model Number	Plunger Size	Piston Size	Amplification Ratio	Supply Pressure PSI(a)	Maximum Discharge Pressure	Maximum Full Strokes Per Minute	Output Volume Qts. Per Day
40	1/4"	1.25"	25:1	15 to 150	0 to 3,750	60	0 to 90
42	1/4"	2.25"	80:1	10 to 150	0 to 10,000	55	0 to 70
44	1/4"	4.00"	240:1	10 to 150	0 to 10,000	35	0 to 30
60	3/8"	1.25"	11:1	15 to 150	0 to 1,600	60	0 to 200
62	3/8"	2.25"	36:1	10 to 150	0 to 5,400	55	0 to 155
64	3/8"	4.00"	110:1	10 to 150	0 to 10,000	30	0 to 67
80	1/2"	1.25"	6.25:1	15 to 150	0 to 935	60	0 to 360
82	1/2"	2.25"	20:1	10 to 150	0 to 3,000	55	0 to 275
84	1/2"	4.00"	60:1	10 to 150	0 to 9,000	30	0 to 120
164	1"	4.00"	16:1	10 to 150	0 to 2,400	40	0 to 680